

FM TONE GENERATOR

TX81Z

SERVICE MANUAL



■ CONTENTS

SPECIFICATIONS	2
PANEL LAYOUT	2
BLOCK DIAGRAM	4
MEMORY CONFIGURATION	6
PRESET VOICE NAME	7
MODE SELECT	8
INITIALIZE VOICE	9
INITIALIZE PERFORMANCE	10
MIDI DATA FORMAT	13
SYSTEM EXCLUSIVE DATA FORMAT	15
MIDI IMPLEMENTATION CHART	27
TEST PROGRAM	28
LSI DATA TABLE	30
IC BLOCK DIAGRAM	31
CIRCUIT BOARDS	32
PARTS LIST	

006727

SINCE 1887



YAMAHA

NIPPON GAKKI CO., LTD. HAMAMATSU, JAPAN

TX81Z Printed in Japan 87.1

SPECIFICATIONS

Switches

POWER, STORE/EG COPY, UTILITY, EDIT/
COMPARE, PLAY/PERFORM, PARAMETER UP,
PARAMETER DOWN, DEC, INC, CURSOR LEFT,
CURSOR RIGHT, CURSOR

Display

16 character x 2 row backlit LCD

Terminals

CASSETTE, MIDI THRU, MIDI OUT, MIDI IN,
OUTPUT I/II, PHONES

Power Requirements

(US and Canadian model) . . . AC 110 - 120V,
50/60Hz
(General model) AC 220 - 240V,
50/60Hz

Power Consumption

8W

Dimensions

480 x 282 x 45.2 mm (W x D x H)
(18-15/16" x 11-1/8" x 1-3/4")

Weight

3.4 kg (7 lbs. 8 oz.)

PANEL LAYOUT

- Front Panel

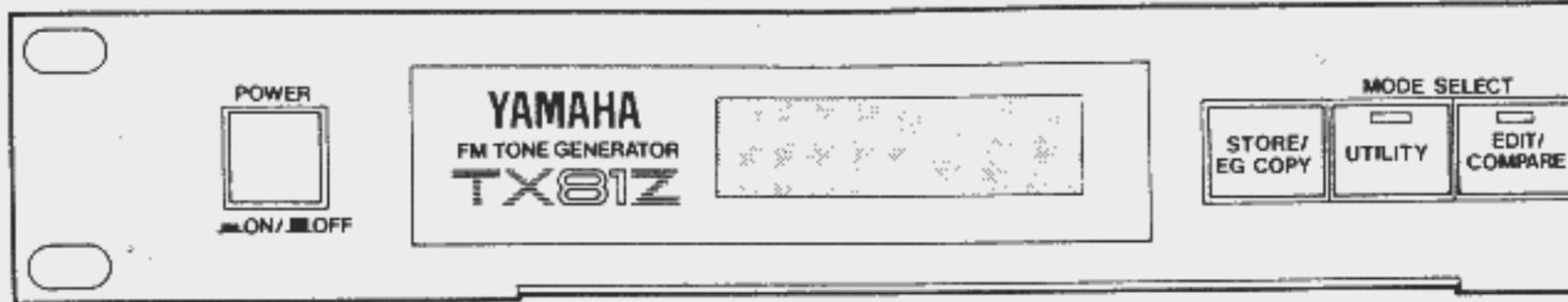

- Rear Panel

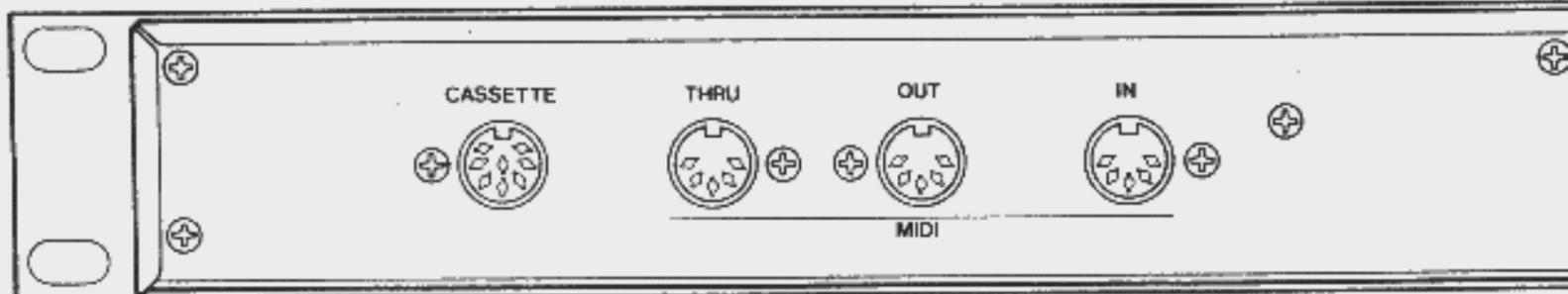

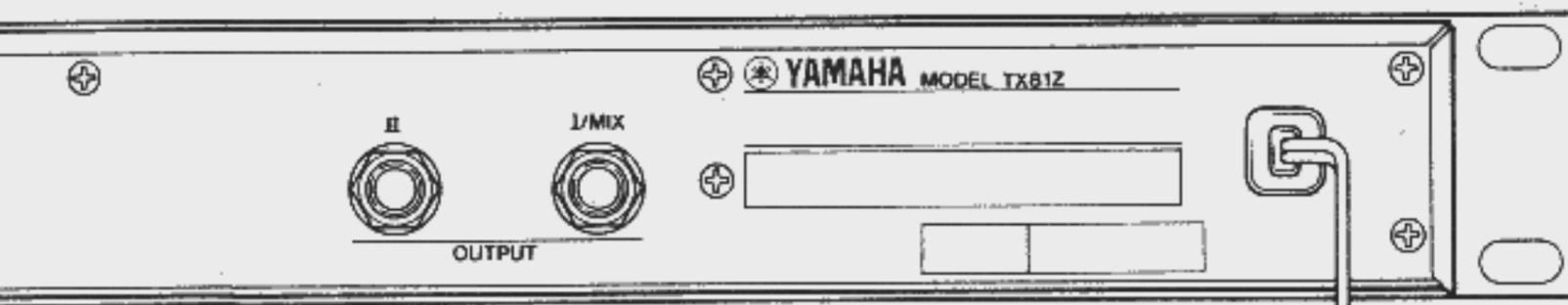
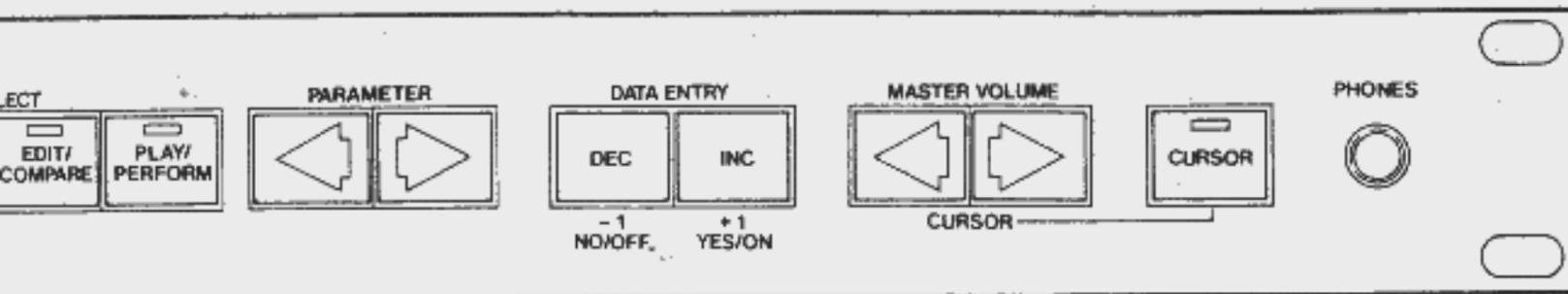

DISPLAY MODE SELECT VOICE PARAMETER DATA ENTRY MASTER VOLUME CURSOR

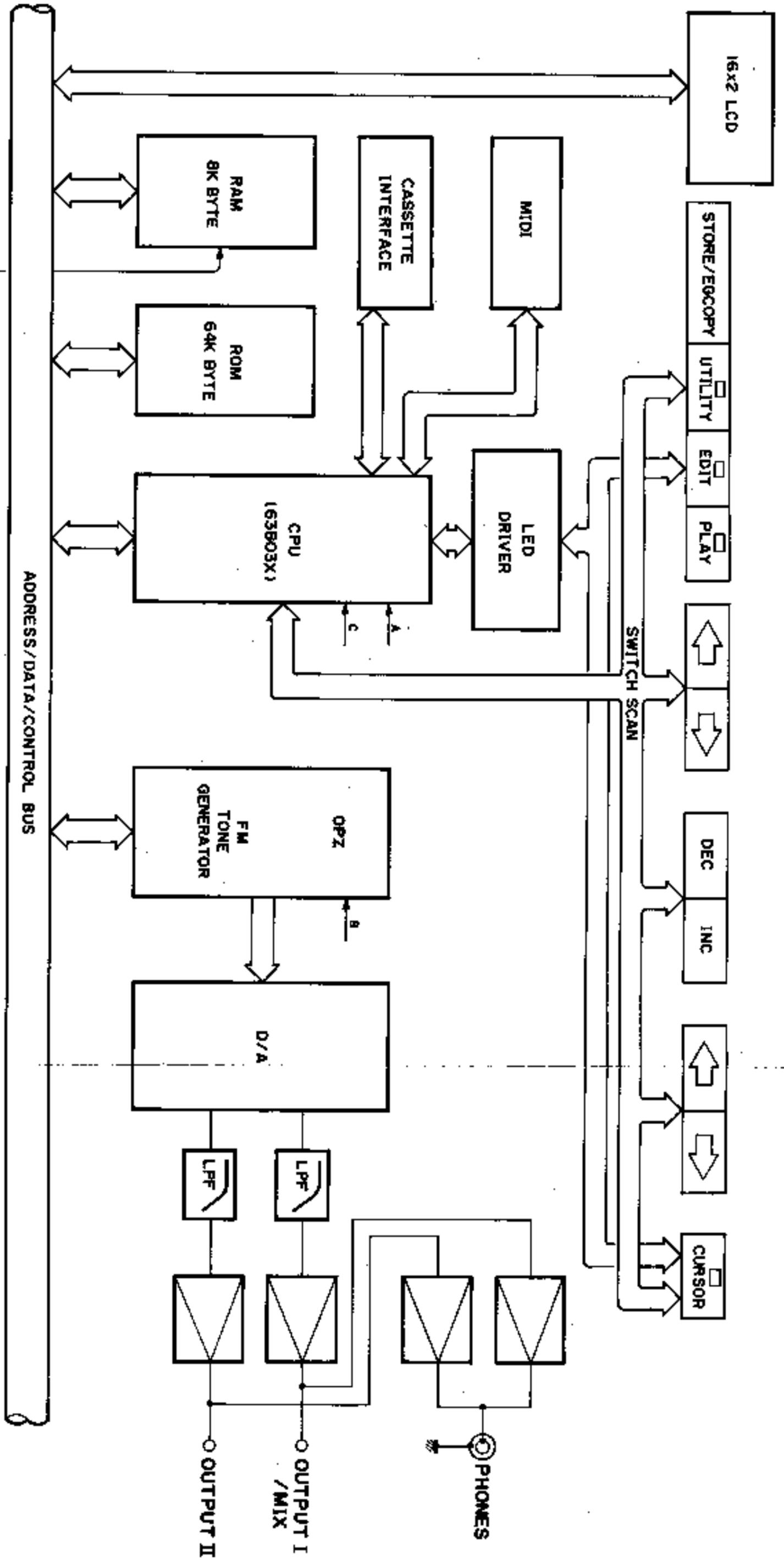

DC 3V
RAM BACK-UP
BATTERY

ADDRESS/DATA/CONTROL BUS

CLOCK GENERATOR
7.15MHz → A
3.58MHz → B
500kHz → C

POWER SUPPLY
VM (23V)
+15V →
-15V →
+5V →
DG →
AC

16x2 LCD

STORE/EGCOPY UTILITY EDIT PLAY

SWITCH SCAN

DEC INC

CURSOR

MIDI

CASSETTE INTERFACE

LED DRIVER

CPU (63B03X)

RAM 8K BYTE

ROM 64K BYTE

OPZ FM TONE GENERATOR

D/A

LPF

LPF

OUTPUT I / MIX

OUTPUT II

PHONES

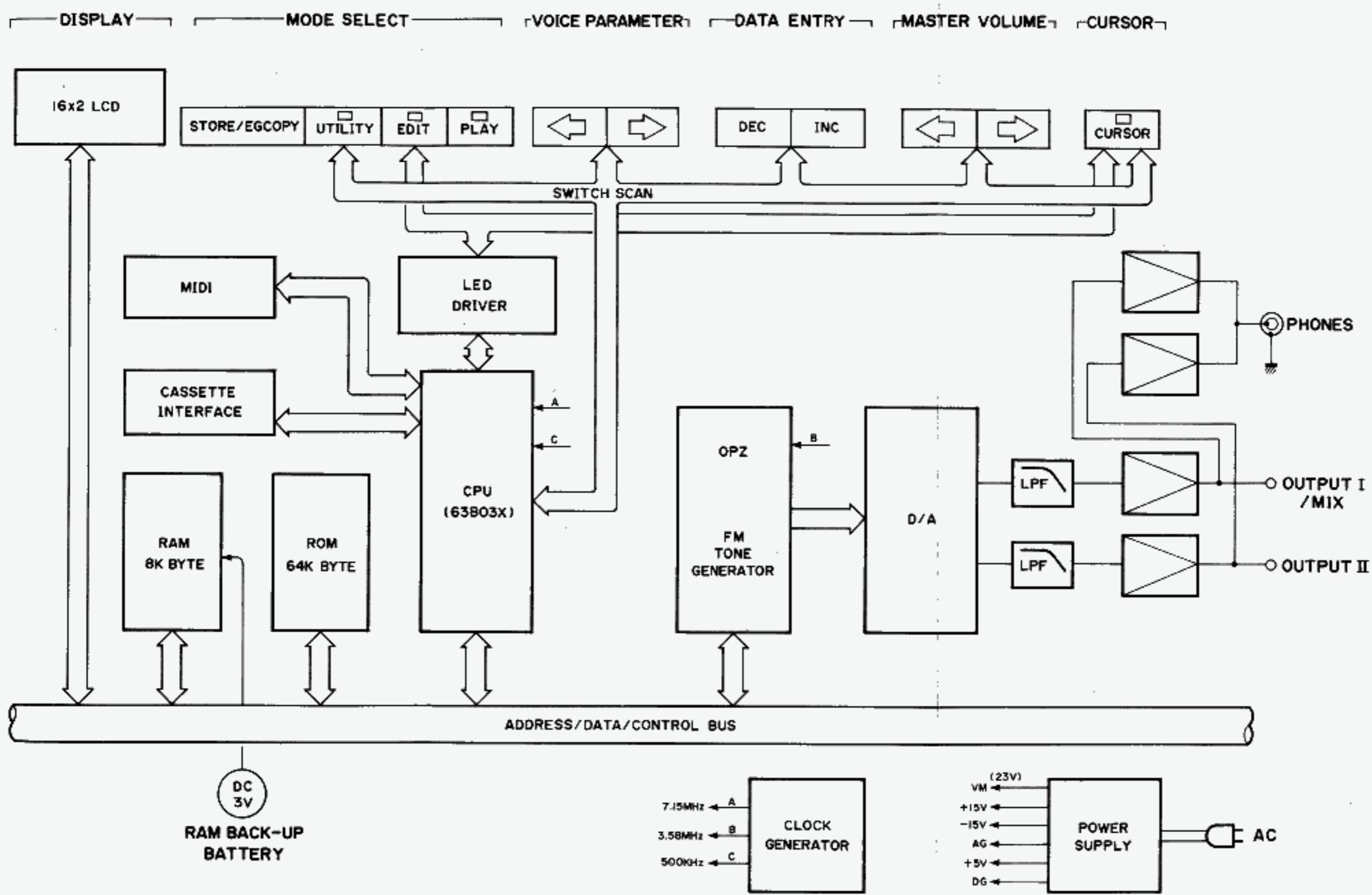

MEMORY CONFIGURATION

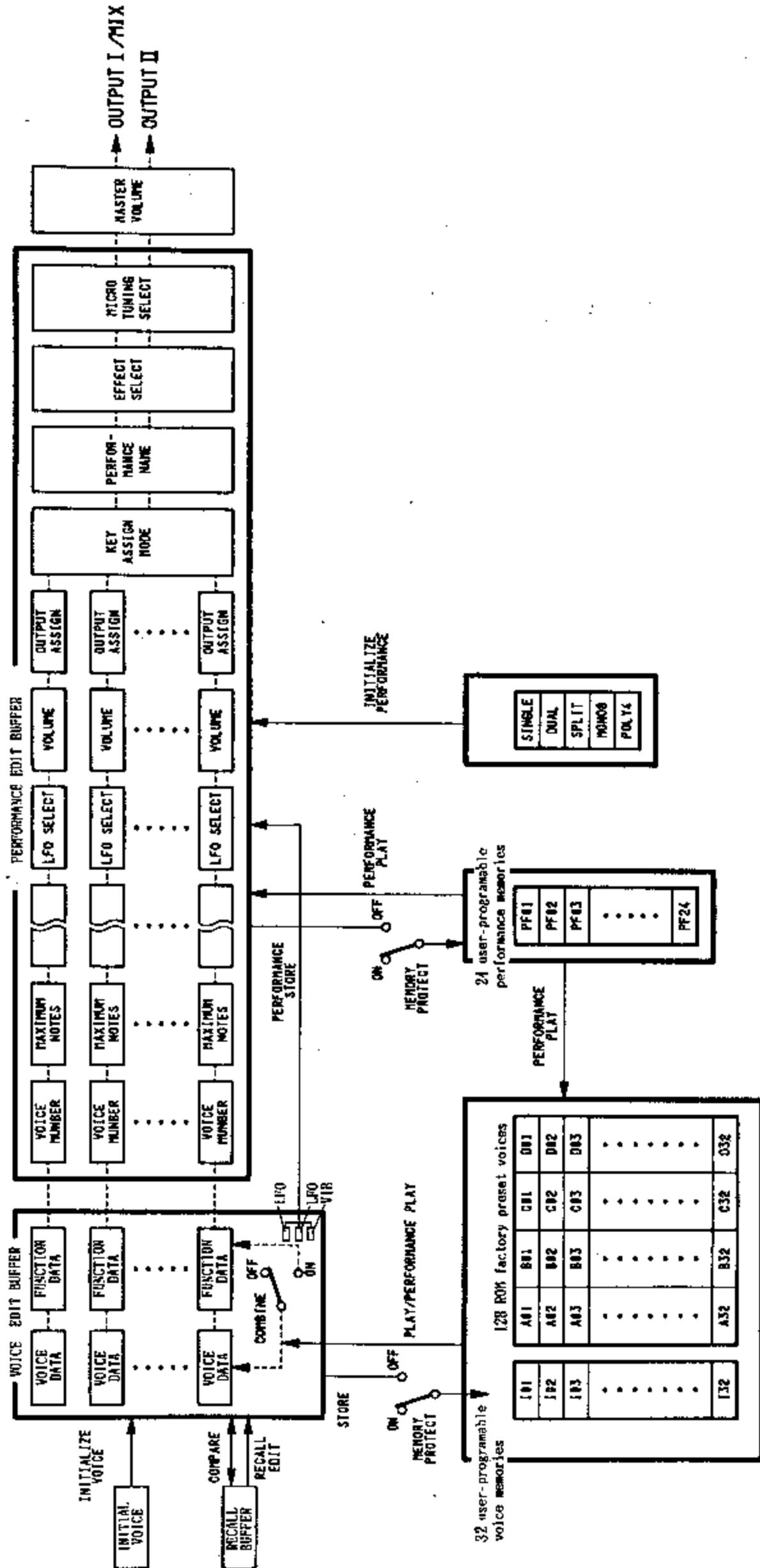

PRESET VOICE NAME

BANK A		BANK B		BANK C		BANK D	
1	GrandPiano	1	Trumpet81Z	1	NylonGuit	1	BaadBreath
2	Uprt Piano	2	Full Brass	2	Guitar #1	2	VocalNuts
3	Deep Grd	3	FlugelHorn	3	TwelveStrg	3	KrstlChoir
4	HonkeyTonk	4	ChorusBras	4	Funky Pick	4	Metalimba
5	Elec Grand	5	FrenchHore	5	AllThatJaz	5	WaterGlass
6	Fuzz Piano	6	AteckBrass	6	HeavyMetal	6	BowedBell
7	SkoolPiano	7	SpitBoneBC	7	Old Banjo	7	>>WOW<<
8	Thump Pno	8	Horns BC	8	Zither	8	Fuzzy Koto
9	LoTine81Z	9	MelloTenor	9	ElecBass 1	9	Spc Midiot
10	HiTine81Z	10	RaspAlto	10	SqncrBass	10	Gurgle
11	ElectroPno	11	Flute	11	SynFunkBas	11	Hole in 1
12	NewElectro	12	Pan Floot	12	ElecBass 2	12	Birds
13	DynomiteEP	13	Basson	13	AnalogBass	13	MalibuNite
14	DynoWurlie	14	Oboe	14	Jaco Bass	14	Helicopter
15	Wood Piano	15	Clarinet	15	LatelyBass	15	Flight Sim
16	Reed Piano	16	Harmonica	16	MonophBass	16	Brthbells
17	PercOrgan	17	DoubleBass	17	StadiumSol	17	Storm Wind
18	16 8 4 2 F	18	BowCello	18	TrumprtSolo	18	Alarm Call
19	PumpOrgan	19	BoxCello	19	BCSexyPhon	19	Recing Car
20	<6 Tease>	20	SoloViolin	20	Lyrisyn	20	Whistling
21	Farcheeza	21	HiString 1	21	WarmSquare	21	Space Talk
22	Small Pipe	22	LowString	22	Sync Lead	22	Space Vibe
23	Big Church	23	Pizzicato	23	MellowSqar	23	Timpani
24	AnalogOrgn	24	Harp	24	Jazz Flute	24	FM Hi-Hats
25	Thin Clav	25	ReverbStrg	25	HeavyLead	25	Bass Drum
26	EZ Clav	26	SynString	26	Java Jive	26	Tube Bells
27	Fuzz Clavi	27	Voices	27	Xylophone	27	Noise Shot
28	LiteHarpsi	28	HarmoPad	28	GreatVibes	28	Snare 1
29	RichHarpsi	29	FanfarTpts	29	Sitar	29	Snare 2
30	Celeste	30	HiString 2	30	Bell Pad	30	Hand Drum
31	BriteCelst	31	PercFlute	31	PlasticHit	31	Synballs
32	Squeezebox	32	BreathOrgn	32	DigiAnnie	32	Efem Toms

MODE SELECT

The TX81Z has two main modes. Each main mode has three "sub-modes".

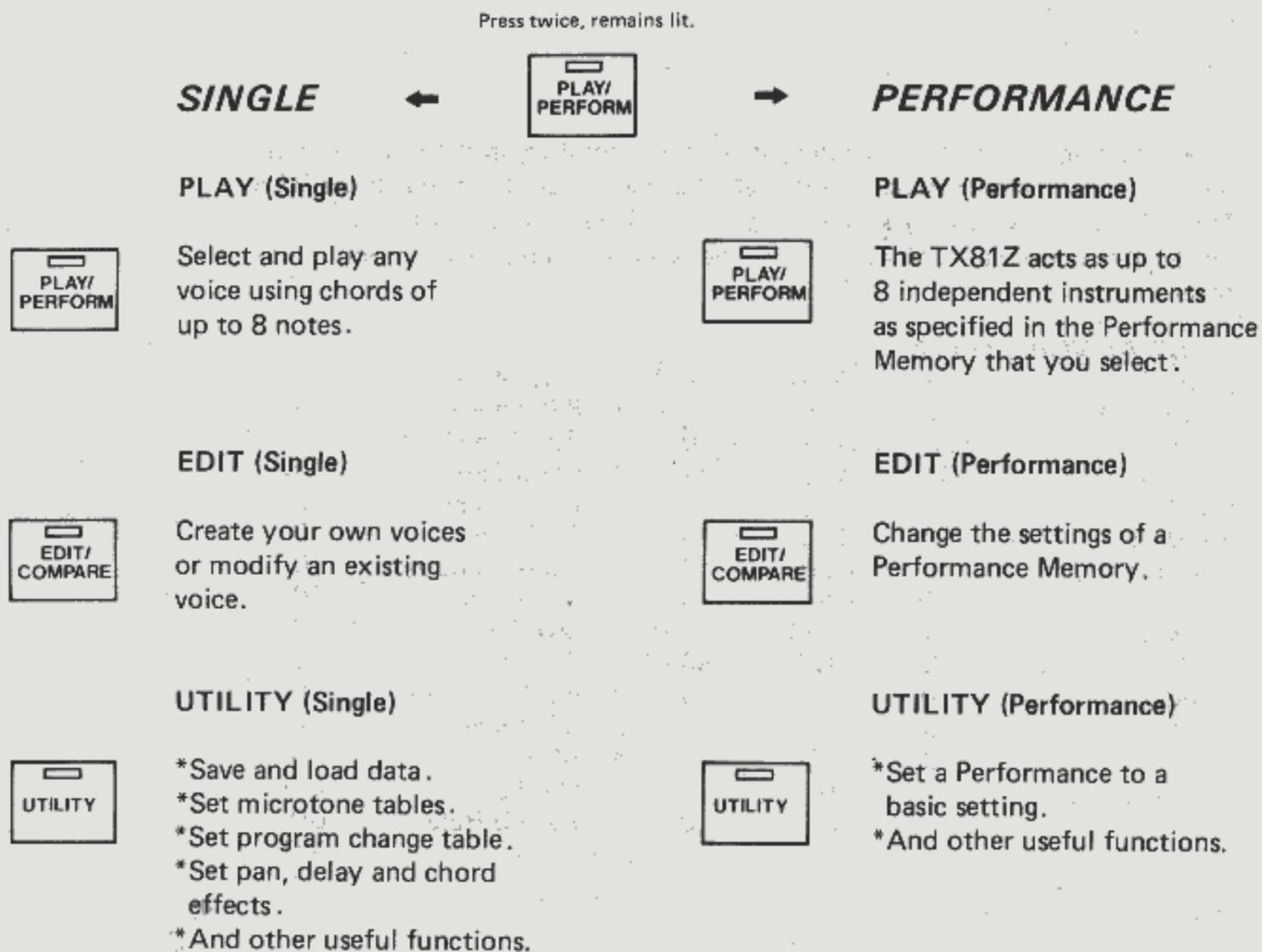

■ INITIALIZE VOICE

This will set the voice data in the edit buffer to the settings shown below.

UTILITY MODE Init Voice?

When creating a voice from scratch, it is often useful to start from this "basic setting" rather than having to reset all the parameters by hand. Press YES. The LCD will ask "Are you sure?", press YES again. The edit buffer will be set to the voice data shown below, and you will automatically enter Edit Mode.

INITIAL VOICE-DATA

ALG = 1	(Mode) = RATIO	Poly Mode
Feedback = 0	OSW = W1 (sine)	P Bend Range = 4
Wave = trianl	DET = 0	Full Time Porta
Speed = 35	AR = 31	Porta Time = 0
Delay = 0	D1R = 31	FC Volume = 40
P Mod Depth = 0	D1L = 15	FC Pitch = 0
A Mod Depth = 0	D2R = 0	FC Amplitude = 0
Sync = off	RR = 15	MW Pitch = 50
P Mod Sens. = 6	SHFT = off	MW Ampli = 0
AMS = 0	OUT = 90 OP 1	BC Pitch = 0
AME : off	0 2	BC Amplitude = 0
EBS = 0	0 3	BC P Bias = 0
KVS = 0	0 4	BC EG Bias = 0
(Frequency) = 1.00	RS = 0	Middle C = C3
	LS = 0	Reverb Rate = off
		Name = INIT VOICE

■ INITIALIZE PERFORMANCE

This lets you initialize the Performance Buffer to one of the standard settings.

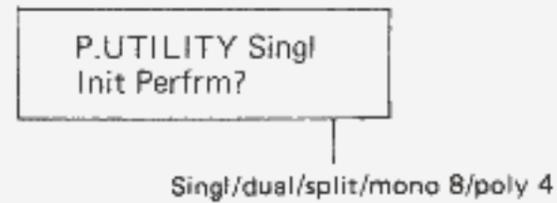

Press NO to select the initialization setting you want. When the LCD shows the desired setting, press YES. You will be asked "Are you sure?" as press YES again.

● Standard Settings

Performance name	SINGLE							
Instrument	1	2	3	4	5	6	7	8
Assign Mode	(Normal) / Alternate							
Max Notes (0-8)	8	0	0	0	0	0	0	0
Voice No. (I01-D32)	I01	I01	I01	I01	I01	I01	I01	I01
Receive Ch. (1-16, omni)	1	2	3	4	5	6	7	8
Limit /L (C-2 – G8)	C-2	C-2	C-2	C-2	C-2	C-2	C-2	C-2
Limit /H (C-2 – G8)	G8	G8	G8	G8	G8	G8	G8	G8
Detune (-7 – +7)	0	0	0	0	0	0	0	0
Note Shift (-24 – +24)	0	0	0	0	0	0	0	0
Volume (0-99)	99	99	99	99	99	99	99	99
Out Assign (off,I,II,I II)	I II	I II	I II	I II	I II	I II	I II	I II
LFO Select (off,1,2,vib)	1	2	vib	vib	vib	vib	vib	vib
Micro Tune (select) Oct	(off)/on	(off)/on	(off)/on	(off)/on	(off)/on	(off)/on	(off)/on	(off)/on
Efect Select	(off) / Delay / Pan / Chord							

Performance name	DUAL							
Instrument	1	2	3	4	5	6	7	8
Assign Mode	Normal / Alternate							
Max Notes (0-8)	4	4	0	0	0	0	0	0
Voice No. (I01-D32)	I01	I01	I01	I01	I01	I01	I01	I01
Receive Ch. (1-16, omni)	1	1	3	4	5	6	7	8
Limit /L (C-2 – G8)	C-2	C-2	C-2	C-2	C-2	C-2	C-2	C-2
Limit /H (C-2 – G8)	G8	G8	G8	G8	G8	G8	G8	G8
Detune (-7 – +7)	0	+2	0	0	0	0	0	0
Note Shift (-24 – +24)	0	0	0	0	0	0	0	0
Volume (0-99)	99	99	99	99	99	99	99	99
Out Assign (I,II,I+II)	I II	I II	I II	I II	I II	I II	I II	I II
LFO Select (off,1,2,vib)	1	2	vib	vib	vib	vib	vib	vib
Micro Tune (select) Oct	off/on	off/on	off/on	off/on	off/on	off/on	off/on	off/on
Effect Select	off / Delay / Pan / Chord							

Performance name	SPLIT							
Instrument	1	2	3	4	5	6	7	8
Assign Mode	Normal / Alternate							
Max Notes (0-8)	4	4	0	0	0	0	0	0
Voice No. (I01-D32)	I01	I01	I01	I01	I01	I01	I01	I01
Receive Ch. (1-16, omni)	1	1	3	4	5	6	7	8
Limit /L (C-2 – G8)	C-3	C-2	C-2	C-2	C-2	C-2	C-2	C-2
Limit /H (C-2 – G8)	G8	B2	G8	G8	G8	G8	G8	G8
Detune (-7 – +7)	0	0	0	0	0	0	0	0
Note Shift (-24 – +24)	0	0	0	0	0	0	0	0
Volume (0-99)	99	99	99	99	99	99	99	99
Out Assign (I,II,I+II)	I II	I II	I II	I II	I II	I II	I II	I II
LFO Select (off,1,2,vib)	1	2	vib	vib	vib	vib	vib	vib
Micro Tune (select) Oct	off/on	off/on	off/on	off/on	off/on	off/on	off/on	off/on
Effect Select	off / Delay / Pan / Chord							

Performance name	MONO8							
Instrument	1	2	3	4	5	6	7	8
Assign Mode	(Normal) / Alternate							
Max Notes (0-8)	1	1	1	1	1	1	1	1
Voice No. (101-D32)	101	102	103	104	105	106	107	108
Receive Ch. (1-16, omni)	1	2	3	4	5	6	7	8
Limit /L (C-2 – G8)	C-2	C-2	C-2	C-2	C-2	C-2	C-2	C-2
Limit /H (C-2 – G8)	G8	G8	G8	G8	G8	G8	G8	G8
Detune (-7 – +7)	0	0	0	0	0	0	0	0
Note Shift (-24 – +24)	0	0	0	0	0	0	0	0
Volume (0-99)	99	99	99	99	99	99	99	99
Out Assign (I, II, I+II)	I II	I II	I II	I II	I II	I II	I II	I II
LFO Select (1, 2, vib)	1	2	vib	vib	vib	vib	vib	vib
Micro Tune (select) Oct	(off)/on	(off)/on	(off)/on	(off)/on	(off)/on	(off)/on	(off)/cn	(off)/on
Effect Select	(off) / Delay / Pan / Chord							

Performance name	POLY4							
Instrument	1	2	3	4	5	6	7	8
Assign Mode	(Normal) / Alternate							
Max Notes (0-8)	2	2	2	2	0	0	0	0
Voice No. (101-D32)	101	102	103	104	105	106	107	108
Receive Ch. (1-16, omni)	1	2	3	4	5	6	7	8
Limit /L (C-2 – G8)	C-2	C-2	C-2	C-2	C-2	C-2	C-2	C-2
Limit /H (C-2 – G8)	G8	G8	G8	G8	G8	G8	G8	G8
Detune (-7 – +7)	0	0	0	0	0	0	0	0
Note Shift (-24 – +24)	0	0	0	0	0	0	0	0
Volume (0-99)	99	99	99	99	99	99	99	99
Out Assign (I, II, I+II)	I II	I II	I II	I II	I II	I II	I II	I II
LFO Select (1, 2, vib)	1	2	vib	vib	vib	vib	vib	vib
Micro Tune (select) Oct	(off)/on	(off)/on	(off)/on	(off)/on	(off)/on	(off)/on	(off)/on	(off)/on
Effect Select	(off) / Delay / Pan / Chord							

■ MIDI DATA FORMAT

The TX81Z responds to MIDI messages as shown in the diagram. BCH indicates Basic Rcv. Ch. and RCH indicates the receive channel for an individual instrument. G1-G16 indicates the Global Channel for Controller or Pitch Bend.

*In the case of Control Change "Pan" (Bn.0A.xx), data values of 0 ~ 42 = output I, 43 ~ 85 = output I + II and 86 ~ 127 = output II.

*System Common messages F1h-F7h and System Realtime messages F8h-FDh and FFh are ignored.

*Once an Active Sensing message FEh is received, the TX81Z will expect a continuing stream of MIDI messages. If no messages come for a period of about 300 msec, it clears the MIDI input buffer and turns off any notes that are currently sounding.

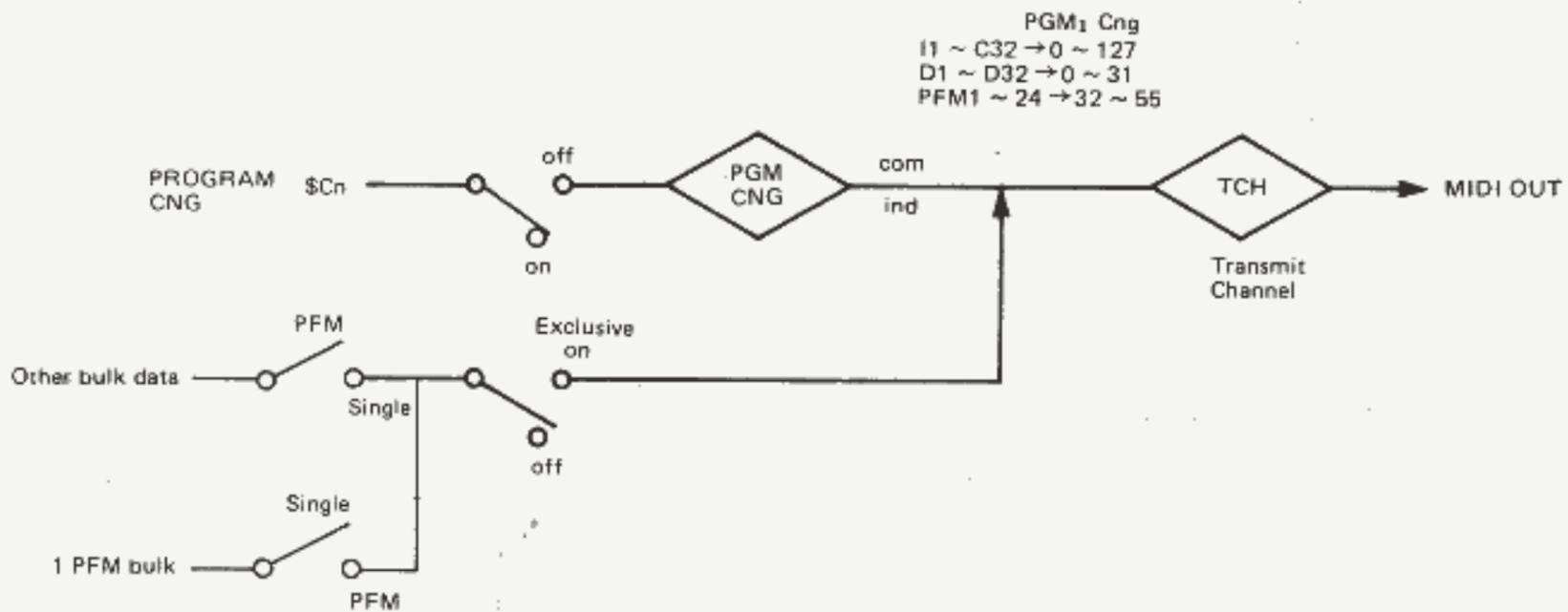

*In PLAY mode when a voice or performance is selected using the front panel keys, the TX81Z will send a program change message: 101-C32 (0-127), D01-D32 (0-31), PF01-PF24 (32-55).

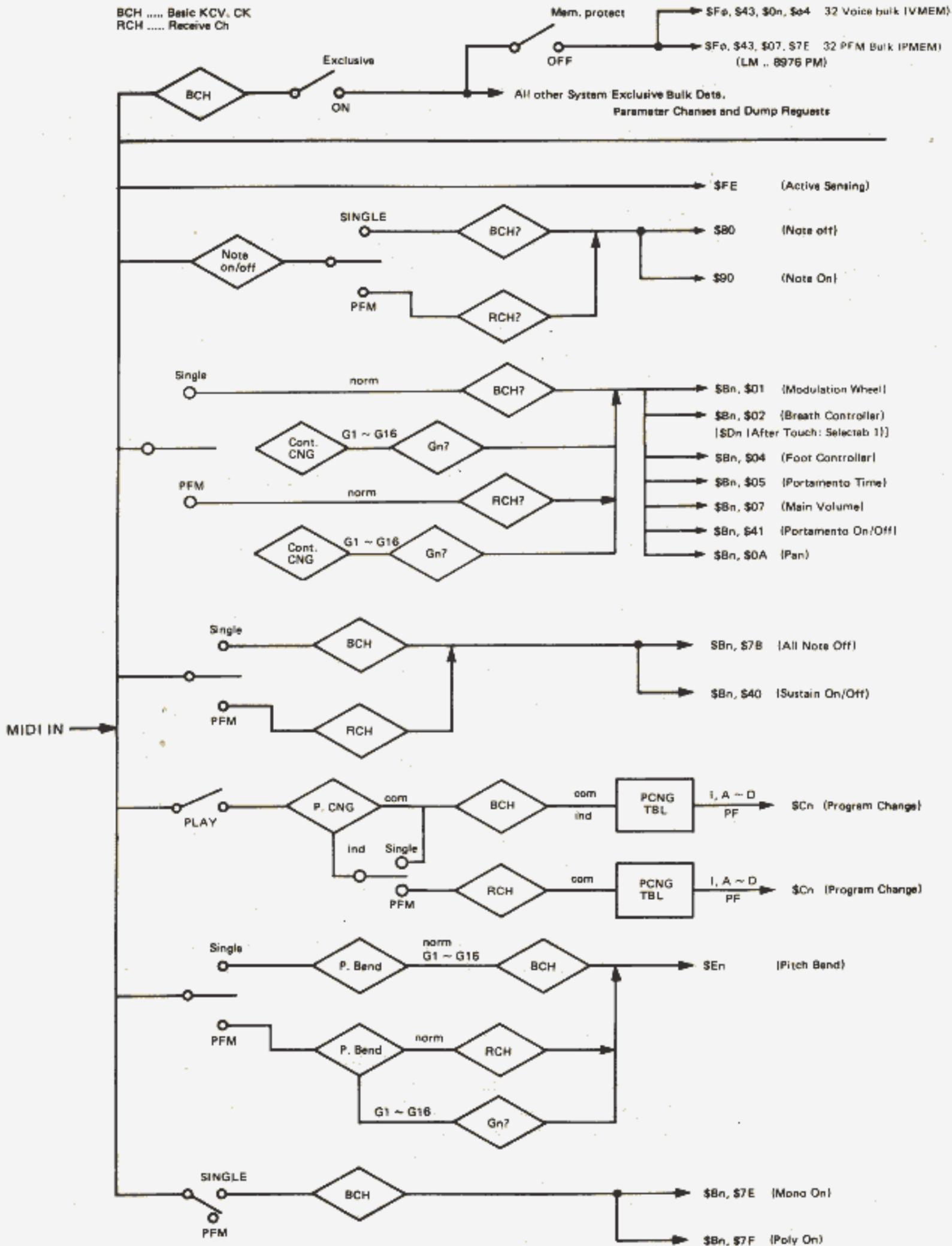

SYSTEM EXCLUSIVE DATA FORMAT

Reading this section will not necessarily help you use the TX81Z. This data is provided to comply with the MIDI Specification, and will be helpful to those who write computer programs to process TX81Z data. The TX81Z has three types of System Exclusive message; Parameter Change messages, Bulk Data messages and Dump Request messages.

PARAMETER CHANGE MESSAGES

These messages change the value of a parameter in TX81Z memory. There are 8 subgroups of Parameter Changes; VCED, ACED, PCED, Remote Switch, Micro Tuning, Program Change, Effect data and System data.

VCED, ACED, PCED and Remote Switch parameter change messages have the following format.

```

11110000  F0h  Exclusive
01000011  43h  I.D. number (Yamaha)
0001nnnn  1nh  Basic receive channel
Oggggghh  ggggg = Group number, hh = Subgroup number
Oppppppp  ppppppp = Parameter number
Oddddddd  ddddddd = Data
11110111  F7h  End Of Exclusive

```

*VCED (Voice parameters compatible with DX21/27/100)
ggggg = 00100 (4), hh = 10 (2)

*ACED (Additional voice parameters for TX81Z)
ggggg = 00100 (4), hh = 11 (3)

*PCED (Performance parameters)
ggggg = 00100 (4), hh = 11 (3)

*Remote Switch (The same effect as pressing a switch on the TX81Z front panel, ie. "remote control".)
ggggg = 00100 (0), hh = 00 (0), ddddddd = 0 (off), 7F (on)

System Parameter Change (basic receive channel settings, etc.) and Effect Parameter Change (data for delay, pan and chord) messages have the following format.

```

11110000  F0h  Exclusive
01000011  43h  I.D. number (Yamaha)
0001nnnn  1nh  Basic receive channel
Oggggghh  ggggg = 00100 (4), hh = 00 (0)
Okkkkkkk  kkkkkkk = Parameter number
              (123 = System Parameter, 124 = Effect Parameter)
Oddddddd  ddddddd = data
11110111  F7h  End of Exclusive

```

***32 Voice (VMEM)**

This message includes both ACED and VCED parameters for 32 voices.
 $f = 4$, data size = $128 \times 32 = 4096$ (1000h), total size = $4096 + 8 = 4104$
 F0. 43. 0n. 04. 10. 00. (VMEM data). checksum. F7

***1 Performance (PCED)**

The contents of the performance edit buffer.
 $f = 126$ (7Eh) "LM..8976PE", data size = 120 (0078h), total size = $120 + 8 = 128$
 F0. 43. 0n. 7E. 00. 78. "LM..8976PE". (data). checksum. F7

***32 Performance (PMEM)**

Data for 24 internal performance memories + 8 initial performances.
 $f = 126$ "LM..8976PM", data size = $10 + (76 \times 32) = 2442$ (098Ah)
 total size = $2442 + 8 = 2450$
 F0. 43. 0n. 7E. 13. 0A. "LM..8976PM", (data). checksum. F7

***System (SYS)**

TX81Z system data (basic receive channel, etc.)
 $f = 126$ "LM..8976S0", data size = $10 + 27 = 37$, total size = $37 + 8 = 45$
 F0. 43. 0n. 7E. 00. 25. "LM..8976S0", (data). checksum. F7

***Program Change Table (SYS)**

Selected memory numbers I1-PF24 for each incoming program change.
 $f = 126$ "LM..8976S1", data size = $10 + 128 \times 2 = 266$ (010Ah), total size = $266 + 8 = 274$
 F0. 43. 0n. 7E. 02. 0A. "LM..8976S1", (data). checksum. F7

***Effect Data (SYS)**

Data for the three effects (delay, pan, chord)
 $f = 126$ "LM..8976S2", data size = $10 + 55 = 65$ (0041h), total size = $65 + 8 = 73$
 F0. 43. 0n. 7E. 00. 41. "LM..8976S2", (data). checksum. F7

***Micro Tune Octave**

Contents of the user octave micro tune memory.
 $f = 126$ "LM..MCRTE0", data size = $24 + 10 = 34$ (0022h), total size = $34 + 8 = 42$
 F0. 43. 0n. 7E. 00. 22. "LM..MCRTE0", (data). checksum. F7

***Micro Tune Full Kbd**

Contents of the user full keyboard micro tune memory.
 $f = 126$ "LM..MCRTE1", data size = $256 + 10 = 266$ (010Ah), total size = 274
 F0. 43. 0n. 7E. 00. 22. "LM..MCRTE1", (data). checksum. F7

**DUMP REQUEST
MESSAGES**

When the TX81Z receives one of these messages with a channel number "n" that matches its Basic Receive channel, it will transmit the requested data as described above in Bulk Data.

VCED	F0. 43. 0n. 03. F7
VMEM	F0. 43. 0n. 04. F7
ACED + VCED	F0. 43. 0n. 7E. "LM_8976AE". F7
PCED	F0. 43. 0n. 7E. "LM_8976PE". F7
PMEM	F0. 43. 0n. 7E. "LM_8976PM". F7
System Setup	F0. 43. 0n. 7E. "LM_8976Sx". F7
Micro Tune	F0. 43. 0n. 7E. "LM_MCRTEx". F7

Voice Edit Parameters (VCED)

Parameter number	Parameter	LCD	Data
0	Attack Rate	AR	0-31
1	Decay 1 Rate	D1R	0-31
2	Decay 2 Rate	D2R	0-31
3	Release Rate	RR	0-15
4	Decay 1 Level	D1L	0-15
5	Level Scaling	LS	0-99
6	Rate Scaling	RS	0-3 OP. 4
7	EG Bias Sensitivity	EBS	0-7
8	Amplitude Modulation Enable	AME	0-1
9	Key Velocity Sensitivity	KVS	0-7
10	Operator Output Level	OUT	0-99
11	Frequency	CRS	0-63
12	Detune	DET	0-6 (Center = 3)
13 			OP. 3
26 			OP. 2
39 			OP. 1
52	Algorithm	ALG	0-7
53	Feedback	Feedback	0-7
54	LFO Speed	Speed	0-99
55	LFO Delay	Delay	0-99
56	Pitch Modulation Depth	P Mod Depth	0-99
57	Amplitude Modulation Depth	A Mod Depth	0-99
58	LFO Sync	Sync	0-1
59	LFO Wave	Wave	0-3
60	Pitch Modulation Sensitivity	P Mod Sens	0-7
61	Amplitude Modulation Sensitivity	AMS	0-3
62	Transpose	Middle C =	0-48 (Center = 24)
63	Poly/Mono	Poly Mode	0-1
64	Pitch Bend Range	P Bend Range	0-12
65	Portamento Mode	Full Time Porta	0-1
66	Portamento Time	Porta Time	0-99
67	Foot Control Volume	FC Volume	0-99
68	Sustain	—	0-1
69	Portamento	—	0-1
70	Chorus	—	0-1 (Set 0)
71	Modulation Wheel Pitch	MW Pitch	0-99
72	Modulation Wheel Amplitude	MW Amplitude	0-99
73	Breath Control Pitch	BC Pitch	0-99
74	Breath Control Amplitude	BC Amplitude	0-99

Parameter number	Parameter	LCD	Data
75	Breath Control Pitch Bias	BC Pitch Bias	0-99 (Center = 50)
76	Breath Control EG Bias	BC EG Bias	0-99
77	Voice name char 1	—	32-127
78	Voice name char 2	—	32-127
79	Voice name char 3	—	32-127
80	Voice name char 4	—	32-127
81	Voice name char 5	—	32-127
82	Voice name char 6	—	32-127
83	Voice name char 7	—	32-127
84	Voice name char 8	—	32-127
85	Voice name char 9	—	32-127
86	Voice name char 10	—	32-127
(Parameters 87-92 not used in the TX81Z.)			
93	Operator On/Off (bits 0-3)	—	0-15 (OP. on = 1)

Voice Edit Additional Parameters (ACED)

Parameter number	Parameter	LCD	Data
0	Fixed Frequency	FIX	0-1
1	Fixed Frequency Range	Fix Range	0-7 0(250Hz)- 7(32kHz)
2	Frequency Range Fine	FIN (RATIO)	0-15 OP. 4
3	Operator Waveform	OSW	0-7
4	EG Shift	SHFT	0-3 0(96dB), 1(48dB) 2(24dB), 3(12dB)
5			OP. 3
10			OP. 2
15			OP. 1
20	Reverb Rate	Reverb Rate	0-7 0(off), 7(fast)
21	Foot Controller Pitch	FC Pitch	0-99
22	Foot Controller Amplitude	FC Amplitude	0-99

Performance Edit Parameters (PCED)

Parameter number	Parameter	LCD	Data
0	Maximum Notes	MAX NOTES	0-8 INST 1
1	Voice Number MSB	—	0-1
2	Voice Number	I01-D32	0-127 } 0-159
3	Receive Channel	RECEIVE CH	0-16 omni = 16
4	Low Note Limit	LIMIT/L	0-127 0(C-2)-127(G8)
5	High Note Limit	LIMIT/H	0-127 0(C-2)-127(G8)
6	Instrument Detune	INST DETUNE	0-14 center = 7
7	Note Shift	NOTE SHIFT	0-48 center = 24
8	Volume	VOL	0-99
9	Output Assign	OUT ASSIGN	0-3 0(off), 1(I), 2(II), 3(I II)
10	LFO Select	LFO SELECT	0-3 0(off), 1(inst1), 2(inst2), 3(vib)
11	Micro Tune Enable	off/on	0-1
12 			INST 2
24 			INST 3
36 ~			INST 4
48 			INST 5
60 			INST 6
72 			INST 7
84 			INST 8
96	Micro Tune Table	MICTUN	0-12
97	Assign Mode	Assign Mode	0-1 0(norm), 1(altr)
98	Effect Select	Effect Sel	0-3
99	Key (for Micro Tune)	—	0-11 (C-B)
100	Performance Name Character 1	—	32-127 (ASCII)
101	Performance Name Character 2	—	32-127 (ASCII)
—			
109	Performance Name Character 10	—	32-127 (ASCII)

Remote Switch Parameters

Parameter number	Parameter	Data
64	POWER ON (reset)	0 (switch off), 127 (switch on)
65	STORE	
66	UTILITY	
67	EDIT	
68	PLAY	
69	PARAMETER -1	
70	PARAMETER +1	
71	DATA ENTRY -1	
72	DATA ENTRY +1	
73	MASTER VOLUME -1	
74	MASTER VOLUME +1	
75	CURSOR	

Voice Bulk Data Format (VMEM)

address	b7	b6	b5	b4	b3	b2	b1	b0	dd (value)	comment
0	0	0	0	-----	AR	-----			0-31	
1	0	0	0	-----	DIR	-----			0-31	
2	0	0	0	-----	D2R	-----			0-31	
3	0	0	0	0	-----	RR	-----		0-15	
4	0	0	0	0	-----	D1L	-----		0-15	OP.4
5	0	-----	-----	-----	LS	-----			0-99	
6	0	AME	-----	EBS	-----	KVS	-----		0-1, 0-7, 0-7	
7	0	-----	-----	-----	OUT	-----			0-99	
8	0	0	-----	-----	F	-----			0-63	
9	0	0	0	RS	-----	DBT	-----		0-3, 0-6	
10										OP.2
~										
~										
20										OP.3
~										
~										
30										OP.1
~										
~										
40	0	SY	-----	FBL	-----	ALG	-----		0-1, 0-7, 0-7	
41	0	-----	-----	-----	LFS	-----			0-99	
42	0	-----	-----	-----	LFD	-----			0-99	
43	0	-----	-----	-----	PMD	-----			0-99	
44	0	-----	-----	-----	AMD	-----			0-99	
45	0	-----	PMS	-----	AMS	-----	LFW	-----	0-7, 0-3, 0-3	
46	0	0	-----	-----	TRPS	-----			0-48	
47	0	0	0	0	-----	PBR	-----		0-12	
48	0	0	0	CH	MO	SU	PO	PM	0-1, 0-1, 0-1, 0-1, 0-1	
49	0	-----	-----	-----	PORT	-----			0-99	
50	0	-----	-----	-----	FC	-----	VOL	-----	0-99	
51	0	-----	-----	-----	MW PITCH	-----			0-99	
52	0	-----	-----	-----	MW AMPLI	-----			0-99	
53	0	-----	-----	-----	BC PITCH	-----			0-99	
54	0	-----	-----	-----	BC AMPLI	-----			0-99	
55	0	-----	-----	-----	BC P BIAS	-----			0-99	
56	0	-----	-----	-----	BC E BIAS	-----			0-99	
57	0	-----	VOICE NAME 1	-----	-----	-----			32-127 (ASCII)	
58	0	-----	VOICE NAME 2	-----	-----	-----				
59	0	-----	VOICE NAME 3	-----	-----	-----				
60	0	-----	VOICE NAME 4	-----	-----	-----				
61	0	-----	VOICE NAME 5	-----	-----	-----				
62	0	-----	VOICE NAME 6	-----	-----	-----				
63	0	-----	VOICE NAME 7	-----	-----	-----				
64	0	-----	VOICE NAME 8	-----	-----	-----				
65	0	-----	VOICE NAME 9	-----	-----	-----				
66	0	-----	VOICE NAME 10	-----	-----	-----			32-127 (ASCII)	
67	0	-----	-----	-----	PR1	-----			0-99	PEG (DX21 only)
68	0	-----	-----	-----	PR2	-----			0-99	Set 99
69	0	-----	-----	-----	PR3	-----			0-99	
70	0	-----	-----	-----	PL1	-----			0-99	Set 50
71	0	-----	-----	-----	PL2	-----			0-99	
72	0	-----	-----	-----	PL3	-----			0-99	

Additional Voice Bulk Data Format

No.	b7	b6	b5	b4	b3	b2	b1	b0	Data	note
0										
.									same as OPM VMEM	
.										
67									PEG PR1 (not used) Set 99	
.									.	
72									PEG PL3 Set 50	
73	0	0							— EGSFT —	
74	0								FIX ——— FIXRG ———	OP.4
									———— OPW ———	
									———— FINE ———	
75										OP.2
.										
77										OP.3
.										
79										OP.1
.										
81	0	0	0	0	0				———— REV ———	
82	0								———— FC PITCH ———	
83	0								———— FC AMPLI ———	

Performance Bulk Data Format (PMEM)

No.	b7	b6	b5	b4	b3	b2	b1	b0	Data	note
0	0	OUT_ASGN		MSB	----	NUM of NOTE	-----			INST1
1	0				-----	VOICE NO	-----			
2	0		---	LFOS	---		-----	RCV CII	-----	
3	0				-----	LIMIT/L	-----			
4	0				-----	LIMIT/H	-----			
5	0						-----	DETUNE	-----	0 ~ 14 (7 center)
6	0	MTE			-----	NOTE SHIFT	-----			
7	0				-----	VOLUME	-----			
8										INST2
16										INST3
24										INST4
32										INST5
40										INST6
48										INST7
56										INST8
64	0	0	0	0			-----	MTBL	-----	
65	0				-----	KEY	-----	EFSEL	-----	ASMODE
66	0				-----	PFM NAME 1	-----			
67	0				-----	PFM NAME 2	-----			
.										
.										
75	0				-----	PFM NAME 10	-----			

TX81Z

System Setup Bulk Data Format (SYS)

No.	b7	b6	b5	b4	b3	b2	b1	b0	Data	note
0	0	-----TUNE-----							0-127	master tune center = 64
1	0	0	0	-----MIDBCH-----					0-16	basic rcv ch 16: omni
2	0	0	0	0	-----MIDTCH-----				0-15	trans ch
3	0	0	0	0	0	0	--PCINF--		0-2	p. cng sw
4	0	0	0	-----COINF-----					0-17	cont. cng sw 1: norm 2-17 (G1 ~ G16)
5	0	0	0	-----PBSW-----					0-17	p. bend sw 1: norm 2-17 (G1 ~ G16)
6	0	0	0	0	0	0	-NOTESW-		0-2	note on/off 0: all, 1: odd, 2: even
7	0	0	0	0	0	0	0 SYSAVL		0-1	exclusive on/off
8	0	0	0	0	0	0	0 MLOCK		0-1	mem. protect
9	0	0	0	0	0	0	0 CMBIN		0-1	combine
10	0	0	0	0	0	0	0 AT		0-1	after touch
11	0	-----ID1-----							32-127	ID (ascii)
12	0	-----ID2-----								
13	0	-----ID3-----								
.										
.										
.										
26	0	-----ID16-----								

Function	Transmitted	Recognized	Remarks
Basic Default	1 - 16	1 - 16	memorized
Channel Changed	1 - 16	1 - 16	
Mode Default	x	1, 2, 3, 4	memorized
Mode Messages		POLY, MONO(M=1)	
Mode Altered	XXXXXXXXXXXXXXXX	x	
Note	x	0 - 127	
Number : True voice	XXXXXXXXXXXXXXXX	13 - 108	
Velocity Note ON	x	0 v=1-127	
Velocity Note OFF	x	x	
After Key's	x	x	
Touch Ch's	x	0 X1	(Breath control)
Pitch Bender	x	0 0-12 semi X2	7 bit resolution
Control Change	1 : x 2 : x 4 : x 5 : x 7 : 10 : x 64 : x 65 : x	0 0 0 0 0 0 0 0	X1 : Modulation wheel X1 : Breath control X1 : Foot control X1 : Portamento time (single mode only) X1 : Volume X1 : Pan(I, I+II, II) (performance mode only) Sustain X1 : Portamento
Prog Change : True #	0 0 - 127 X3 XXXXXXXXXXXXXXXX	0 0 - 127 0 - 183	if pgm cng sw is on. (assignable)
System Exclusive	0 X4	0 X4	Voice parameters
System : Song Pos	x	x	
System : Song Sel	x	x	
Common : Tune	x	x	
System : Clock	x	x	
Real Time : Commands	x	x	
Aux : Local ON/OFF	x	x	
Aux : All Notes OFF	x	0 (123, 126, 127)	
Mes- : Active Sense	x	0	
sages:Reset	x	x	

Notes: X1 = receive if cont. change switch is on.
 X2 = receive if pitch bend sw is on.
 X3 = transmit if program change switch is on and system exclusive switch is off.
 X4 = transmit/receive if system exclusive switch is on.

27 Mode 1 : OMNI ON, POLY Mode 2 : OMNI ON, MONO o : Yes
 Mode 3 : OMNI OFF, POLY Mode 4 : OMNI OFF, MONO x : No

TX81Z

TEST PROGRAM

1. Preparation Instructions

- (1) Connect the MIDI IN connector to the MIDI OUT connector with a MIDI cable.
- (2) Connect the CASSETTE connector to the 10dB amplifier with a DIN cable.

*Use an 10dB amplifier or set a cassette deck to REC/PAUSE and adjust it so that there is 10dB gain.

2. Test Program Entry

- (1) Starting from Test 1

While pressing and holding the MASTER VOLUME ← and CURSOR switches, turn on the POWER switch. The LCD will display a message as shown below.

P.UT
Test Entry ?

Press the INC switch, and the preset voice data is loaded into the RAM and the MIDI parameters are set as shown in the chart below.

Ch. Info:	ON
Basic Rcv. Ch.:	all (OMNI ON)
Transmit Ch.:	1
Sys. Info:	ON

- (2) Starting from Test 5

While pressing and holding the MASTER VOLUME ← and → switches, turn on the POWER switch. The Test routine will start from the Test Program 5.

3. Test Program 1: Output check

- (1) The LCD will display the message shown below.

Check LVL 1 (L)

An output signal of $-19 \pm 2\text{dBm}$ at 440Hz (A3 note) can be detected at the OUTPUT I (L) connector. If the INC switch is pressed, the Test Program will proceed to the next step.

- (2) The LCD will display the message shown below.

Check LVL 2 (R)

An output signal of $-19 \pm 2\text{dBm}$ at 440Hz (A3 note) can be detected at the OUTPUT II (R) connector. If the INC switch is pressed, the Test Program will proceed to the next step.

- (3) The LCD will display the message shown below.

Check LVL HP (L)

An output signal of $-13 \pm 2\text{dBm}$ at 440Hz (A3 note) can be detected at the Lch. of the HEAD-PHONES connector. If the INC switch is pressed, the Test Program will proceed to the next step.

- (4) The LCD will display the message shown below.

Check LVL HP (R)

An output signal of $-13 \pm 2\text{dBm}$ at 440Hz (A3 note) can be detected at the Rch. of the HEAD-PHONES connector. If the INC switch is pressed, the Test Program will proceed to the next routine.

4. Test Program 2: RAM check, CASSETTE I/F check and MIDI I/O check.

- (1) When this test is initiated, the RAM check, CASSETTE I/F check and the MIDI I/O check are performed automatically. If an error is detected, the Test Program will stop at that step. If the CASSETTE I/F check is in error, pressing the DEC switch will advance the Test Program to the next step.
- (2) The LCD will display the message shown below.

Check MIDI THRU

The MSX monitor and the program for the MIDI THRU connector and check on the MSX monitor for continuous output of the test data (AA, FF, 00, 55) from the MIDI THRU connector. If the INC switch is pressed, the Test Program will advance to the next routine.

*MIDI THRU check

Connect the MSX monitor to the MIDI THRU connector and check on the MSX monitor for continuous output of the test data (AA, FF, 00, 55) from the MIDI THRU connector. If the INC switch is pressed, the Test Program will advance to the next routine.

5. Test Program 3: LCD check

The entire LCD turns "ON and OFF" three times. If the INC switch is pressed, the LCD will display as shown below.



When proper lighting of the LCD display has been verified, press the INC switch, and the Test Program will proceed to the next routine.

6. Test Program 4: LED check

The LCD will display the message shown below.



The switch LED indicators will light one after another from left to right, then all of the switch LED indicators will light simultaneously. When proper lighting of the LEDs has been verified, press the INC switch, and the Test Program will proceed to the next routine.

7. Test Program 5: Panel switch check

When this test is entered, switch number 1 will appear in the LCD display as shown below.

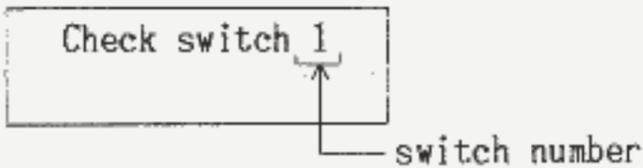

Press the switch that is indicated by the LCD display. If an incorrect switch is pressed, the Test Program will not advance. Pressing the correct switch will advance the Test Program to the next routine.

Switch Number	Switch Name
1	STORE/EG COPY
2	UTILITY
3	EDIT/COMPARE
4	PLAY/PERFORM
5	PARAMETER ←
6	PARAMETER →
7	DEC
8	INC
9	MASTER VOLUME ←
10	MASTER VOLUME →
11	CURSOR

Upon completion of these tests, the test routine will reset the system to the normal operating mode.

LSI DATA TABLE

• YM2414 (XB768001) Operator

PIN NO.	NAME	I/O	FUNCTION	PIN NO.	NAME	I/O	FUNCTION
1	V _{SS}		GND	24	ϕM	I	Clock 3.58 MHz
2	IR ₀	O	Interrupt data	23	ϕ1	I	Synchro pulse for DAC
3	IC	I	Initial clear	22	VDD	I	DC Supply (+5V)
4	AD0	I	Address bus	21	S0	O	Tone signal data
5	WR	I	Write control	20	SH1	O	Sample and hold (Ch1)
6	RD	I	Read control	19	SH2	O	Sample and hold (Ch2)
7	CS	I	Chip Select	18	D7	I/O	Data bus
8	CT1	O	Control data out 1	17	D6	I/O	
9	CT2	O	Control data out 2	16	D5	I/O	
10	D0	I/O	Data bus	15	D4	I/O	
11	V _{SS}		GND	14	D3	I/O	
12	D1	I/O	Data bus	13	D2	I/O	

• HD63B03XP (IG140800) Central Processing Unit

PIN NO.	NAME	I/O	FUNCTION	PIN NO.	NAME	I/O	FUNCTION
1	V _{SS}	I	Ground	33	V _{CC}	O	DC Supply (+5V)
2	XTAL	I	Clock (8MHz)	34	A15	O	Address bus
3	EXTAL	I					
4	MP0	I	Mode program	35	A14	O	
5	MP1	I					
6	RES	I	Reset	36	A13	O	
7	STBY	I	Stand-by mode signal	37	A12	O	
8	NMI	I	Non-maskable interrupt	38	A11	O	
9	P20	I/O	Port 2	39	A10	O	
10	P21	I/O					
11	P22	I/O					
12	P23	I/O					
13	P24	I/O					
14	P25	I/O					
15	P26	I/O					
16	P27	I/O	Port 5	40	A9	O	
17	P50	I/O					
18	P51	I/O					
19	P52	I/O					
20	P53	I/O					
21	P54	I/O					
22	P55	I/O					
23	P56	I/O	Port 6	41	A8	O	
24	P57	I/O					
25	P60	I/O					
26	P61	I/O					
27	P62	I/O					
28	P63	I/O					
29	P64	I/O					
30	P65	I/O	Data bus	42	V _{SS}	O	
31	P66	I/O					
32	P67	I/O					
				43	A7	O	
				44	A6	O	
				45	A5	O	
				46	A4	O	
			47	A3	O		
			48	A2	O		
			49	A1	O		
			50	A0	O		
			51	D7	I/O		
			52	D6	I/O		
			53	D5	I/O		
			54	D4	I/O		
			55	D3	I/O		
			56	D2	I/O		
			57	D1	I/O		
			58	D0	I/O		
			59	BA	O	Bus available	
			60	LIR	O	Load instruction resistor	
			61	R/W	O	Read/Write control	
			62	WR	O	Write	
			63	RD	O	Read	
			64	E	O	Enable	

● YM3012 (IT301200) Digital to Analog Converter

PIN NO.	NAME	I/O	FUNCTION	PIN NO.	NAME	I/O	FUNCTION
1	VDD	I	DC supply (+5V)	9	CH1	O	Sample and hold analog SW output (ch1)
2	CLOCK	I	Timing clock	10	CH2	O	" " (ch2)
3	D GND	I	Digital ground	11	COM	I	Ch1 ch2 analog SW common input
4	SD	I	Serial data input	12	A OUT	O	Analog output to Buffer AMP
5	SAM2	I	Sample and hold (ch2)	13	MP	I	Middle point 1/2 VDD bias
6	SAM1	I	" " (ch1)	14	BC	I	Bias compensation
7	ICL	I	Initial clear	15	RB	O	Bias-R
8	A. GND	I	Analog ground	16	A. GND	I	Analog ground

■ IC BLOCK DIAGRAM

- TC40H004P (IG051000)
- SN74HC04N (IR000450)
Hex Inverter

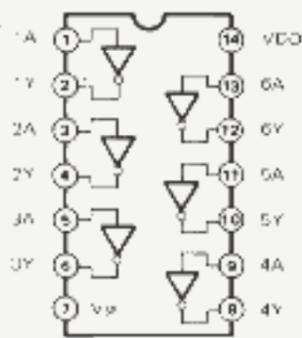

- SN74HC14N (IR001450)
Hex Inverter

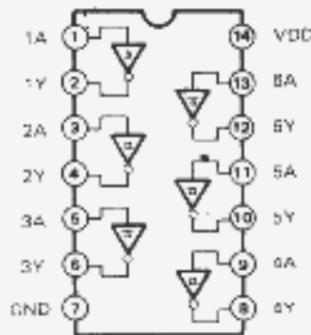

- SN74HC32N (IR003250)
Quad 2 Input OR

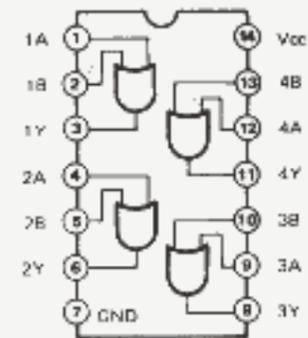

- TC40H074P (IG051100)
Dual D-Type Flip-Flop

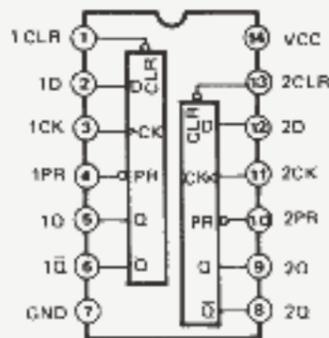

INPUTS				OUTPUTS	
PR	CLR	CLK	D	Q	Q̄
L	H	X	X	H	L
H	L	X	X	L	H
L	L	X	X	H	H
H	H	F	H	H	L
H	H	F	L	L	H
H	H	L	X	Q ₀	Q̄ ₀

- SN74HC138N (IR013850)
3 to 8 Demultiplexer

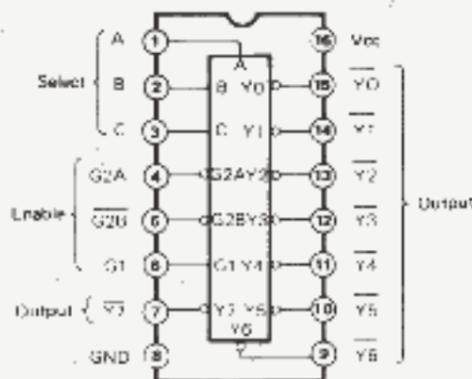

- NJM072D (IG107000)
Dual Operational Amplifier

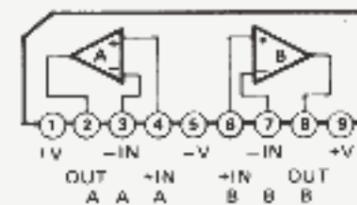

TX81Z

XBRIZ

● PN Circuit Board

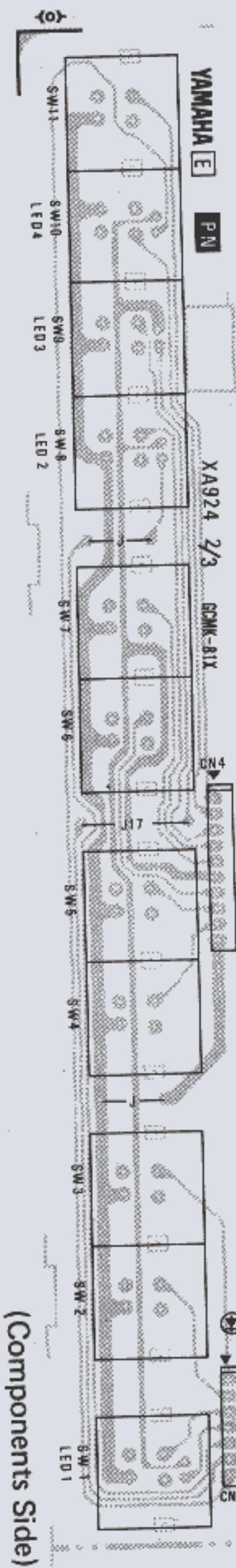

(Components Side)

● JK Circuit Board

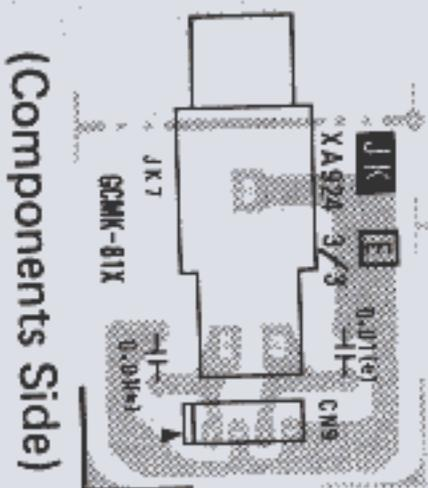

(Components Side)

Notes)

DM, PN, JK Circuit Boards

1. Circuit Boards: XA924D
2. IC
 - IC1: NJM4558DV (IG001390)
 - IC2, 10: NJM072D (16107000)
 - IC3: NJM4556DV (IG042500)
 - IC4: TC40H004P (IG051000)
 - IC5: TC40H074P (IG05110)
 - IC6: PST518B-2 (IG116200)
 - IC7: SN74HC14N (IR001450)
 - IC8: TLP552 (IK000470)
 - IC9: IR9311 (IG134900)
 - IC11: SN74HC138N (IR013850)
 - IC12: YM3012 (IT301200)
 - IC13: YM2414 (XB768001)
 - IC14: RAM TC5564PL-15 (XB013001)
 - IC15: ROM 64K (XB186002)
 - IC16: HD63B03XP (IG140800)
 - IC17: SN74HC32N (IR003250)
 - IC18: SN74HC04N (IR000450)
3. Transistor
 - Q1, 2: 2SC2878 (A, B)
 - Q3 ~ 6: 2SA1115 (E, F)
 - Q7 ~ 9: 2SC2603 (E, F)
4. Diode
 - D1 ~ 3: 1SS176
5. LED
 - LED1 ~ 4: LN242RP (RE)
6. (セ) marked: Semiconductive Cera. Cap.
7. 6.8Ω 1W: Metal Oxide Resistor
47Ω 1W: Metal Oxide Resistor
8. Resistor Array
 - RA1: RMNG12472/103J (4.7K x 6 +10K x 6)
 - RA2: RMNG10472/103J (4.7K x 5 +10K x 5)
 - RA3: RMLA-391J (390 x 4)
9. CL1: Ceramic Resonator 500kHz
CR1: Quartz Crystal Unit 7.15909MHz
10. EMI1: EMI Filter 0.022μF
11. Lithium Battery
 - B1: CR2032



ments Side)

Circuit Board

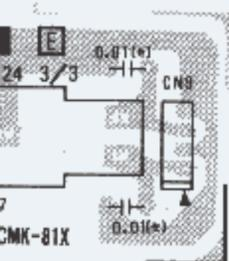

● AD Circuit Board

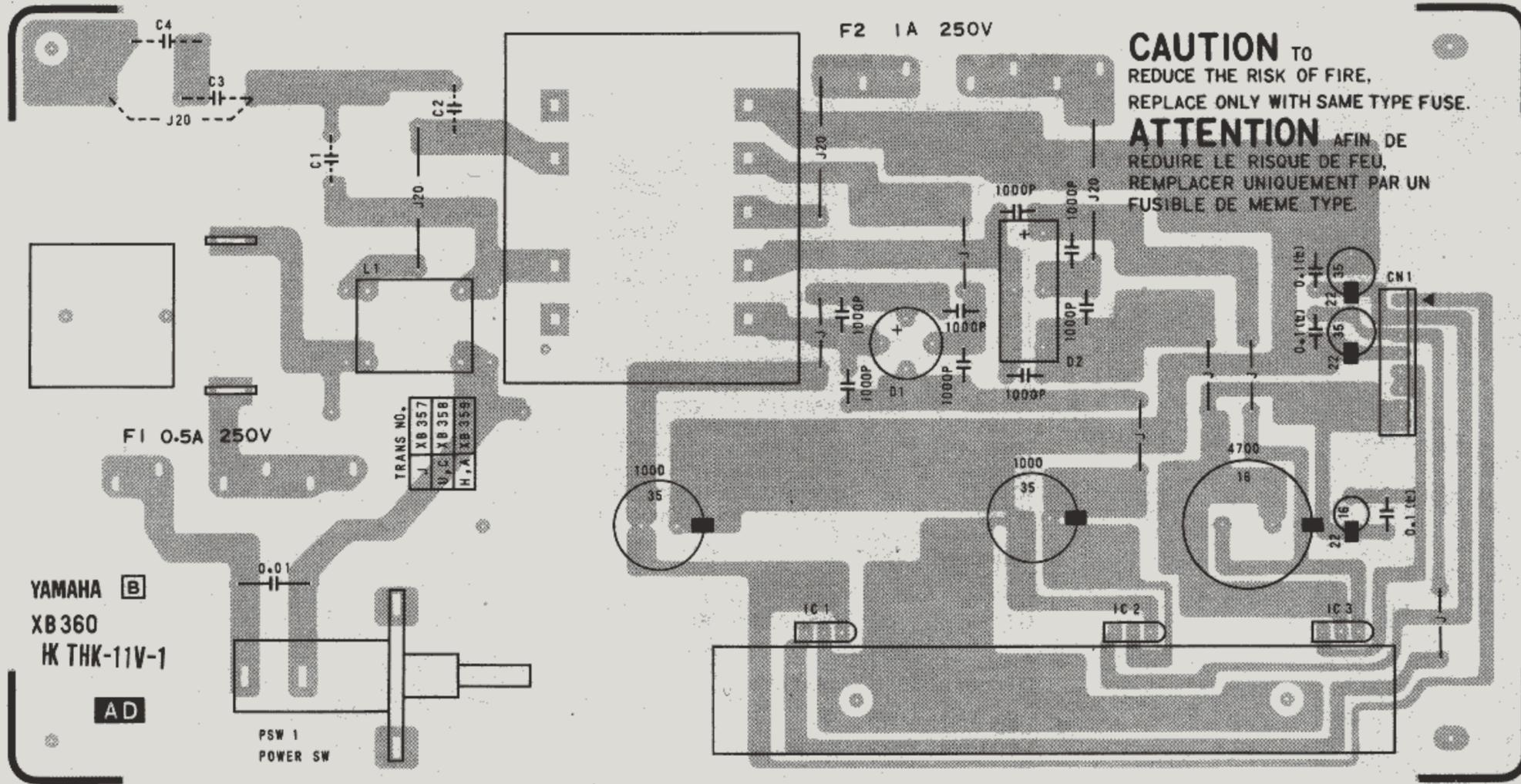

(Components Side)

Notes)

AD Circuit Board

1. Circuit Board: XB360B
2. IC
IC1: AN78M15F (XB466001)
IC2: AN79M15F (XB467001)
IC3: AN78M05F (XB646001)
3. Diode
D1: 1D4B1
D2: SIRBA10
4. (セ) marked: Semiconductive Cera. Cap.
5. Coil
L1: PLA3021A

Spec.	C1, C2	C3, C4	F1	F2	T1
Japanese	2200P	X	▽ 0.5A 250V	▽ 1A 250V	XB357
U.S.A. Canadian	2200P	X	UL ST4 0.5A 250V	UL ST4 1A 250V	XB358
North European West German Australian	2200P	4700P	Ⓢ T500mA 250V	Ⓢ T630mA 250V	XB359

TX81Z

FM TONE GENERATOR

TX81Z

PARTS LIST

Notes DESTINATION ABBREVIATIONS

J : Japanese model	A : Australian model
U : U.S.A. model	E : European model
C : Canadian model	D : West German model
X : General model	B : British model
M : South African model	I : Indonesian model
H : North European model	

OVERALL ASSEMBLY

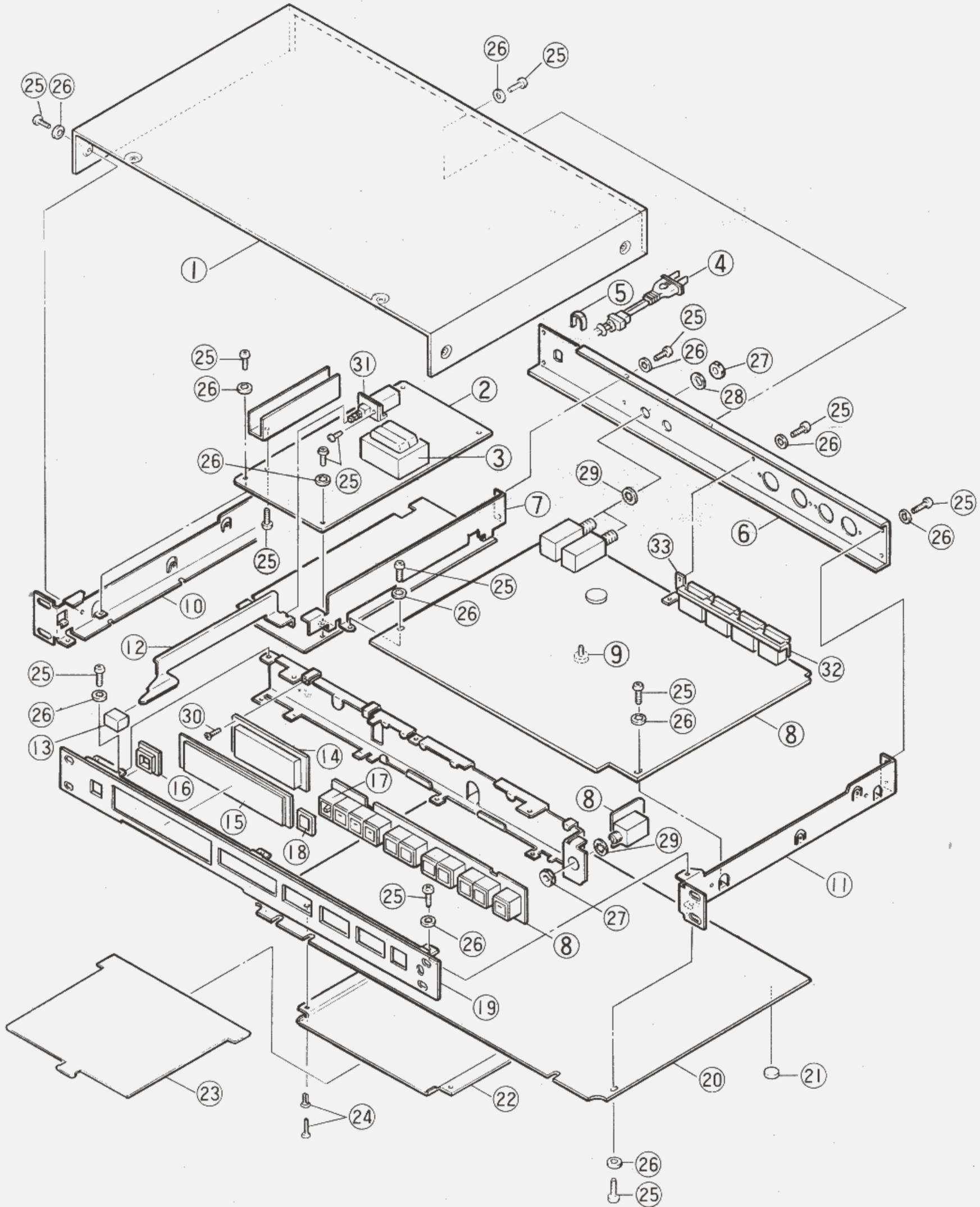

TX81Z